

BODE PATENTED SELF-ALIGNING ROTATORS

- Instantly self-aligning to the workpiece.
- Robust all-steel welded construction.
- Clutches incorporated in top rollers of Drive Section to prevent damage to transmission when loading.
- Variable speed rotation through AC inverter control.
- Tachometer speed indicator (optional).
- Anti-Creep fitted to Idler Section (optional).

| Model SAR/TSAR | Drive Capacity (tons) | Load Capacity per Section (tons) | Minimum Diameter (mm) d | Maximum Diameter (mm) D ₂ | Roller Diameter (mm) | Roller Width (mm) | Roller Material | Overall Length Drive (mm) L ₁ | Overall Width Drive (mm) W ₁ | Overall Length Idler (mm) L ₂ | Overall Width Idler (mm) W ₂ | Height over Rollers (mm) H | Track Gauge (T/SAR) (mm) |
|----------------|-----------------------|----------------------------------|-------------------------|--------------------------------------|----------------------|-------------------|-----------------|--|---|--|---|----------------------------|--------------------------|
| 60 | 3 | 1,5 | 200 | 2400 | 254 | 76 | Rubber | 1745 | 570 | 1040 | 440 | 513 | 1435 |
| 100 | 5 | 2,5 | 380 | 3100 | 254 | 102 | Rubber | 1754 | 630 | 1224 | 450 | 565 | 1435 |
| 200 | 10 | 5 | 450 | 4600 | 381 | 127 | Rubber | 3524 | 770 | 1980 | 540 | 871 | 1435 |
| 300 | 15 | 7,5 | 450 | 4600 | 457 | 152 | Rubber | 2660 | 800 | 2110 | 572 | 905 | 1435 |
| 400 | 20 | 10 | 450 | 4600 | 381 | 76 | Polyurethane | 2884 | 830 | 2010 | 600 | 871 | 1435 |
| 500 | 25 | 12,5 | 450 | 4600 | 381 | 102 | Polyurethane | 2884 | 830 | 2010 | 600 | 871 | 1435 |
| 600 | 30 | 15 | 450 | 5200 | 457 | 127 | Polyurethane | 2820 | 900 | 2170 | 600 | 965 | 1435 |
| 800 | 40 | 20 | 450 | 5200 | 457 | 127 | Polyurethane | 3050 | 1000 | 2205 | 680 | 1035 | 1435 |
| 1000 | 50 | 25 | 450 | 5200 | 457 | 152 | Polyurethane | 3050 | 1000 | 2205 | 680 | 1035 | |
| 1200 | 60 | 30 | 500 | 5500 | 559 | 127 | Polyurethane | 3100 | 1100 | 2530 | 800 | 1186 | |
| 1600 | 80 | 40 | 500 | 5500 | 559 | 178 | Polyurethane | 3200 | 1250 | 2610 | 900 | 1329 | |
| 2000 | 100 | 50 | 600 | 6000 | 559 | 260 | Polyurethane | 3745 | 1300 | 2800 | 940 | 1356 | |
| 2400 | 120 | 60 | 600 | 6000 | 559 | 260 | Polyurethane | 3745 | 1300 | 2800 | 940 | 1356 | |
| 3000 | 150 | 75 | 600 | 6000 | 559 | 310 | Polyurethane | 3745 | 1650 | 3020 | 1200 | 1384 | |
| 4000 | 200 | 100 | 1000 | 7000 | 559 | 360 | Polyurethane | 4100 | 1700 | 3280 | 1250 | 1414 | |
| 5000 | 250 | 125 | 1000 | 7000 | 559 | 180 | Steel | 4150 | 1500 | 3290 | 1000 | 1414 | |
| 6000 | 300 | 150 | 1000 | 7000 | 559 | 203 | Steel | 4200 | 1550 | 3290 | 1050 | 1414 | |
| 8000 | 400 | 200 | 1000 | 7500 | 559 | 254 | Steel | 4515 | 1725 | 3510 | 1140 | 1567 | |
| 10000 | 500 | 250 | 1000 | 8000 | 700 | 178 | Steel | 5400 | 1900 | 4000 | 1320 | 1720 | |
| 12000 | 600 | 300 | 1000 | 8000 | 710 | 254 | Steel | 6000 | 2100 | 4100 | 1500 | 1790 | |

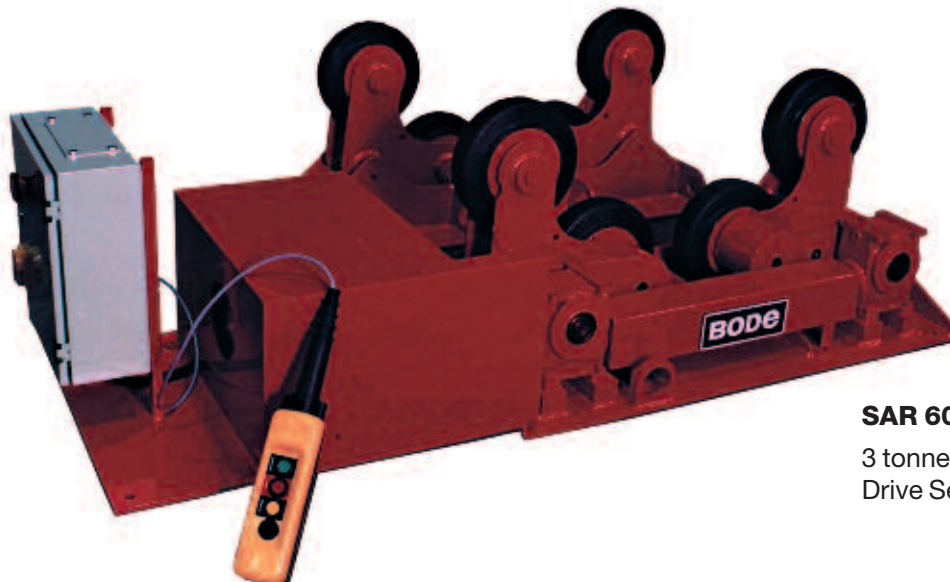
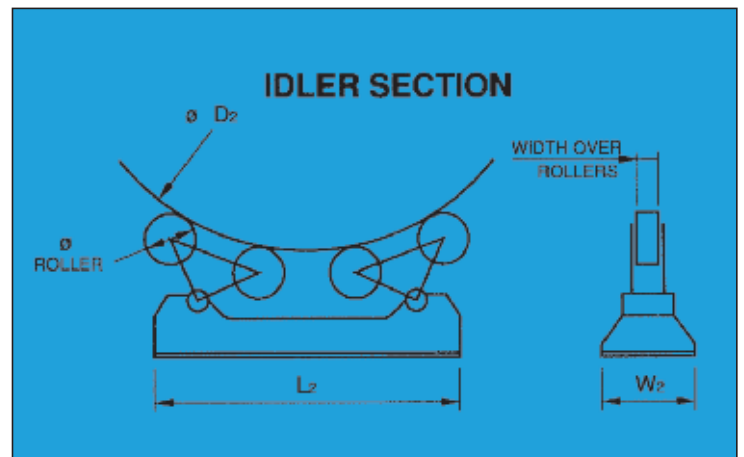
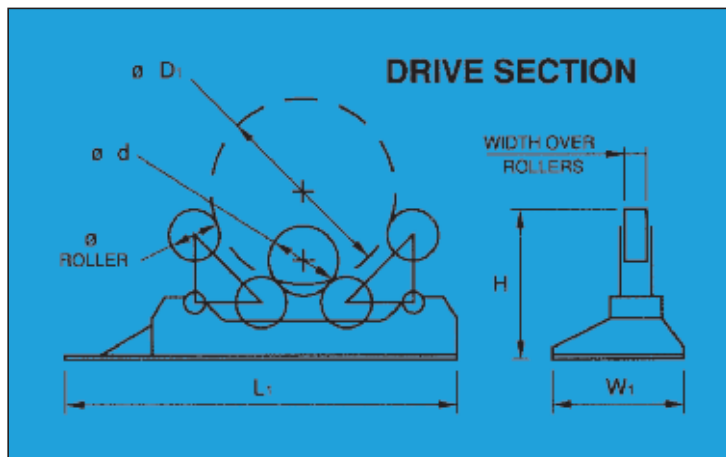

SAR 60

3 tonnes capacity.

Drive Section equipped with inverter control.



SAR 2000

Deaerator Storage Tank Section – supported on Model **SAR 2000** Self-Aligning Rotators.
(Courtesy of: GEC ALSTHOM Heat Exchange Limited).

Construction:

BODE Self-Aligning (patented) Rotators provide an economical and practical answer for cylindrical vessel rotating problems.

The unique design permits the rollers to align themselves to the workpiece without any manual pre-adjustment whatsoever and irrespective of ovality or irregularity. The vessel remains central to the frames irrespective of diameter, and frequent adjustment of the welding head becomes unnecessary.



SAR 4000 Special

80 tonnes capacity.
Drive Section equipped with thyristor control. Idler Section Incorporates Anti-Creep device.



SAR 5000/H

250 tonnes capacity.
Drive Section equipped with thyristor control. Idler Section incorporates Anti-Creep device. A hydraulic facility is incorporated which enables the vessel sections to be readily aligned.

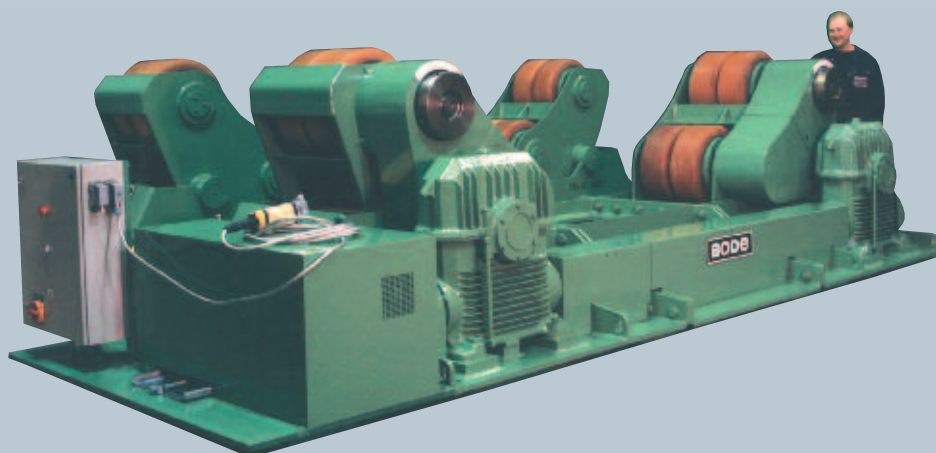

BODE PATENTED TRAVERSING SELF-ALIGNING ROTATORS

***On Track to Turn Out
a Perfect Engineered
Product***

BODE
BODE
BODE
BODE
POSITIONERS
BODE
SERVICE
BODE
HIRE



T/SAR 3000

150 tonnes capacity
Self-Aligning Rotators mounted on traversing bogie.

Bode's Traversing Self-Aligning Rotators follow the well established reputation of their static counter-parts for ease of use and reliability.

Like their counter-parts they provide an economical and practical platform for all cylindrical vessel rotating problems. Their patented and unique designs allow the rollers to automatically align themselves to any work-piece, without any form of manual adjustment and irrespective of irregularity in the shape of the circular workpiece.

This exceptional facility not only saves time, but in ensuring that the item being worked on remains central to the rotator frames, eliminates any need for welding head adjustment.

The Traversing Self-Aligning Rotator range are all bogie-mounted to carry vessels of various lengths, and to allow for traversing, in addition to rotation at the work site. The 'low loading' bogie design integral

to the rotator construction ensures that unlike standard bogies, their closeness to the ground eliminates the risk of excess vessel loading heights.

As is to be expected of Bode machinery, all Traversing Self-Aligning Rotators are built to the highest standards with quality materials and components:

- Robust, all-steel construction
- Inverter controlled traversing and rotation at welding speeds.
- All rollers of the Drive Section positively driven.
- Clutches incorporated in top rollers of the Drive Section to prevent damage to transmission during loading.
- On unloading easy-pivot roller brackets operate in reverse, moving to their resting position, ready to take next piece.
- Idler Section can incorporate manual or electric anti-creep feature to restrict vessel 'creep' to +/- 1 mm.

T/SAR/S. Split Frame Models

The 2400, 6000 and 12000 in this range incorporate Split Frames with leadscrew adjustment to allow the trunnion bracket assemblies to be moved across the frames.

This additional Bode feature permits a far wider range of vessel diameters to be supported on all four wheels. A secondary leadscrew adjustment is in place to move both trunnion assemblies 40 mm off centre line. This provides for lining up of the vessel strokes.

Whatever your requirement – large or small, short or long – you will find that Bode has the solution in Stationary or Traversing Self-Aligning Rotators.

Get in touch today to discuss your production needs and let Bode meet your needs in full.



BODE
POSITIONERS
BODE
SERVICE
BODE
HIRE

F. Bode & Sons Limited

Unit No 1 Stubbins Lane
Claughton-On-Brock
Preston, Lancs
England
PR3 0QH

Tel.: +44 (0) 1995 643 210

Fax: +44 (0) 1995 643 211

E-mail - sales@bode.co.uk

Visit our web site - www.bode.co.uk